

SAFETY FEATURES

- Electronic and mechanical door interlocks on elevator cars and ground enclosure unit
- Overload device to prevent elevator operation when rated payload has been exceeded
- Spring buffer assembly
- Low and medium speed elevators do not require counterweights
- Galvanized tower sections and tie-ins

DESIGN FEATURES

- Smooth starting and stopping without surging or jarring the elevator car
- The lifting speed can be easily controlled and is infinitely variable
- The elevator starting current is lower than the rated current
- Using the frequency conversion drive greatly reduces mechanical wear and tear on the elevator and its components
- The frequency conversion drive is more efficient and uses less power.

INSTALLATION

- For instructions regarding the erection, climbing, dismantling, operation and maintenance of the elevator car refer to the operations manual.
- This product must be operated by competent, orientated personnel and used in a safe manner to conform with the manufacturers specifications and in compliance with all federal, state standards and regulations.
- Drawings are for illustrative purposes only and do not necessarily show the exact configurations of products offered on the market at a particular time.

Lewis Crane and Hoist LLC. not only owns and maintains one of the largest elevator fleets in the United States, but also exclusively offers the Hercules elevators. Hercules elevators are the newest, fastest, highest capacity of counterweightless elevators available in America.

At Lewis Crane and Hoist LLC., we believe that our business is not only equipment but also service. Because of this belief, Lewis Crane and Hoist LLC. offers services for all rigging, mechanical, electrical and engineering needs. We make it our business to ensure that the services we offer are far superior to any of our competitors because we understand that your project is only as good as the equipment used to build it.

Additional Equipment and Services Available

- Moritsch Tower Cranes
- Comedil Tower Cranes
- Peiner Tower Cranes
- Sun Tower Cranes
- Comansa Tower Cranes
- Timberland Derricks
- Hardrock Elevators
- Hercules Elevators
- Specialized Rigging
- Technical Services
- Third Party Inspections
- Parts and Repair Services
- Erection and Dismantlement Services

*Due to product improvement specifications are subject to change without notice.

EQUIPMENT RENTALS - SALES- 24 HOUR SERVICE - YARD STORAGE & TRANSFERS - REGIONAL SERVICE

2214 FM 1187, SUITE 1
MANSFIELD, TX 76063
OFFICE: 817-225-1090 FAX: 817-225-1095

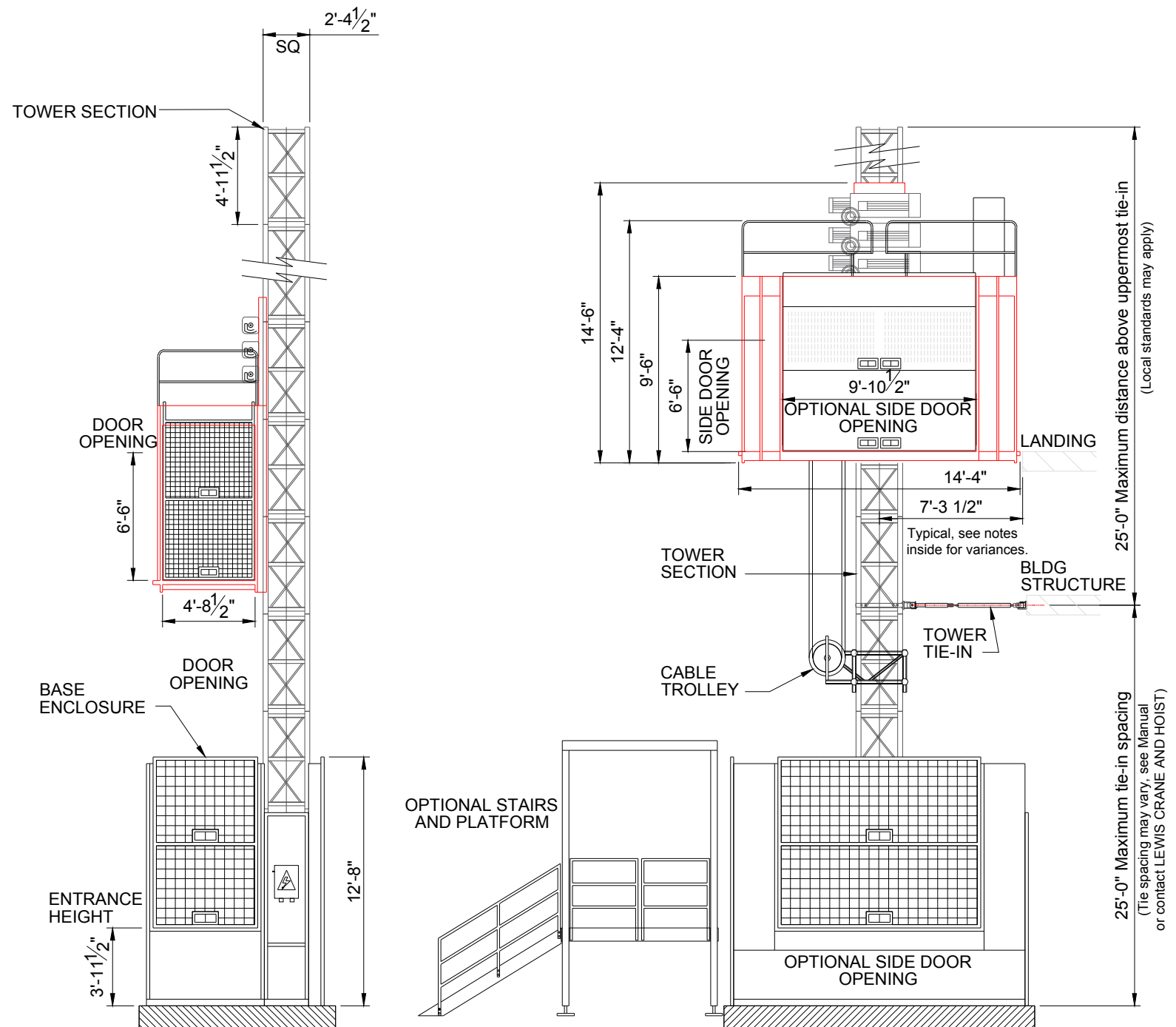

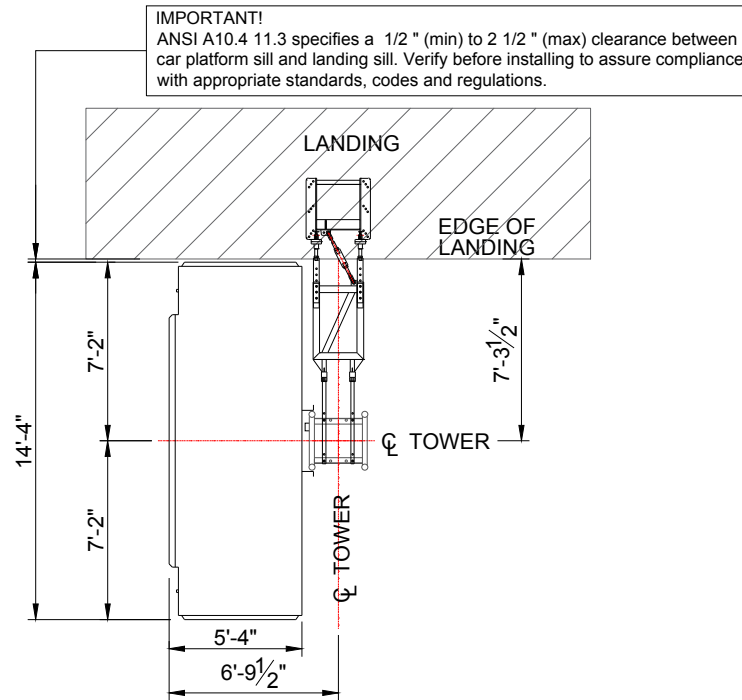

TIE-IN PLAN VIEW

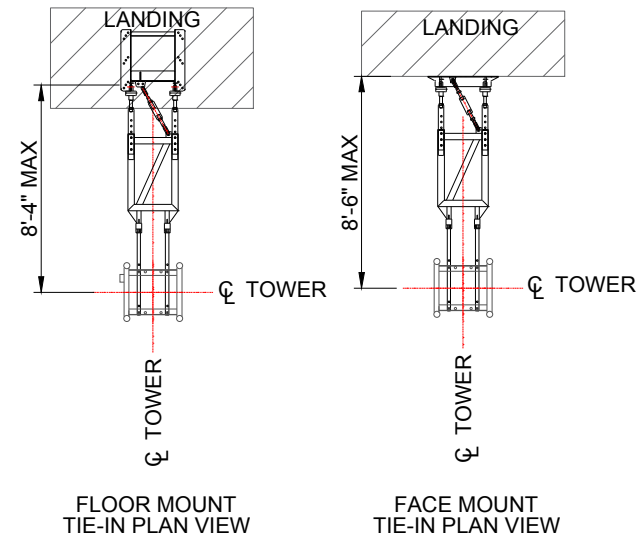

NOTE:
Distances above are for typical type 5 tie-in. Alternate anchoring methods are available. Contact LCH for information.

MODEL VARIATIONS

F7000 SLS (WITHOUT COUNTERWEIGHT)
F7000 SHS (WITH COUNTERWEIGHT)

150 FPM (LOW SPEED)
315 FPM (HI SPEED)

GENERAL

LOAD CAPACITY
INSIDE ELEVATOR CAR DIMENSIONS
DOOR OPENING (END)
OPTIONAL SIDE DOOR OPENING
TOWER SECTION LENGTH
MAXIMUM TOWER HEIGHT
MAXIMUM TOWER TIE-IN SPACING

7,000 lbs (PER CAR)
4'-10" wide x 7'-9" high x 13'-9" long
4'-8 1/2" x 6'-6"
9'-10 1/2" x 6'-6"
4'-11 1/2"
490'-0" (For greater heights consult LCH)
25'-0"

WEIGHTS

GROUND ENCLOSURE
BASE UNIT
ELEVATOR CAR
COUNTERWEIGHT (SHS ONLY)
TOWER SECTION (8 mm)
CATHEAD (SHS ONLY)
TIE-IN (TYPE 5)

1,980 lb
1,200 lb
5,291 lb
4,400 lb each
510 lb
265 lb
212 lb per set

ELECTRICAL

POWER REQUIREMENT (PER CAR)
MOTORS (PER CAR)

480 VOLT - 150 AMPS - 3 PHASE - 60 HZ
3 x 30 HP

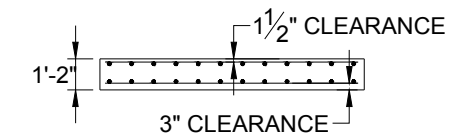

FOUNDATION ELEVATION VIEW

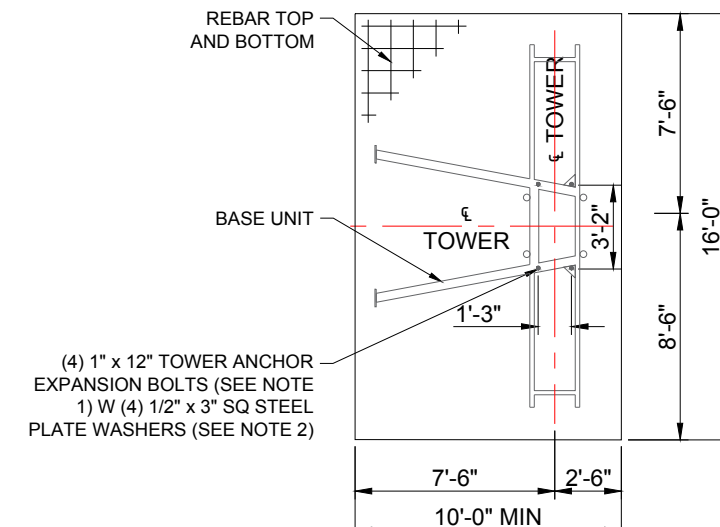

FOUNDATION PLAN VIEW

NOTES:

- 1" x 12" HILTI Kwik Bolt II anchor bolt or approved equal. Install according to bolt manufacturer's requirements.
- Foundation slab: 10'-0" x 15'-0" x 1'-2" with 3,500 psi concrete.
- Reinforcing bars are #5 ASTM 615-60 10" o.c. each way.
- Foundation based on 490 foot mast height. For greater heights contact Lewis Crane and Hoist for design.
- Foundation pad designed for a minimum soil bearing of 1,000 psf.
- Refer to manufacturers manual before installing, operating, servicing, repairing, jumping or dismantling.

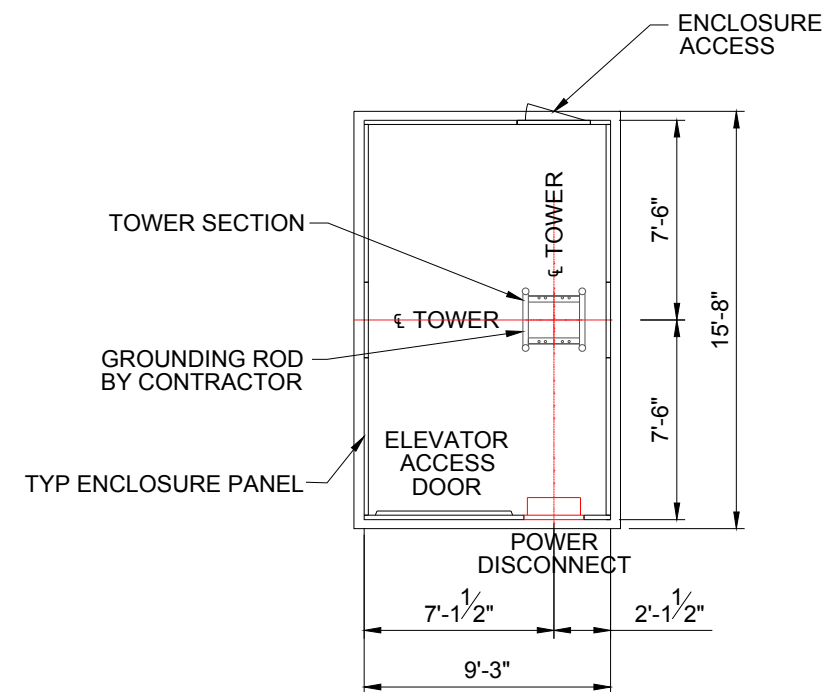

GROUND ENCLOSURE PLAN VIEW